

DINEXPRESS BEVERAGE COUNTERS

Compliant with
NSF/ANSI Standard 2



DXP3CU

Item Numbers

DXP2CU
DXP3CU
DXP4CU
DXP5CU
DXP6CU

DineXpress Beverage Counters are designed to keep your serving area clean and functional and will accommodate a number of dispensers. The standard full-length drains will keep hazardous spills from your floors.

Standard Features

- 14-gauge stainless steel top with 1-1/2" turndown on all sides
- Top secured by four recessed bolts
- 14-gauge stainless steel legs fastened to 18-gauge stainless steel bottom shelf
- 20-gauge stainless steel end and front panels are attached to legs
- Top is furnished with 1" deep drain trough and grate fitted with a 1/2" drain valve
- Open control side for additional storage capacity
- 5" diameter swivel plate casters, 2 with brakes
- Interlocking mechanism is provided to interlock with other DineXpress units

Dimensions

- DXP2CU – 36"H x 28"D x 32"L
- DXP3CU – 36"H x 28"D x 46"L
- DXP4CU – 36"H x 28"D x 60"L
- DXP5CU – 36"H x 28"D x 74"L
- DXP6CU – 36"H x 28"D x 88"L
- 36" height on all standard units
- 30" height is available on Petite Elite units
- 28" width
- 32" to 88" length in 14" increments

Options

- Pizzazz powder coating in lieu of stainless steel
- Tray slides
- Hinged or sliding doors
- Reinforced Top

Warranty

One year parts and labor.

*We do not accept returns on any Dinex equipment or Dinex custom products.
Please contact your local Dinex rep to ensure order accuracy prior to ordering.*

DINEX®

4711 E. Hefner Road
Oklahoma City, OK 73131
800.654.8210 | 405.475.5600
www.dinex.com

Rev 11/19

DINEXPRESS BEVERAGE COUNTERS

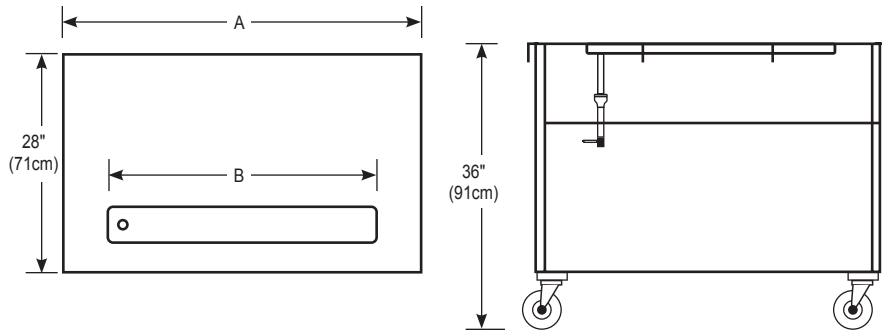

Items and Dimensions

ITEM NUMBER	LENGTH (A)	WIDTH	HEIGHT	DRAIN LENGTH (B)	SHIP WEIGHT (LBS)
DXP2CU	32" (32cm)	28" (71cm)	36" (91cm)	18" (46cm)	225
DXP3CU	46" (117cm)	28" (71cm)	36" (91cm)	32" (81cm)	265
DXP4CU	60" (152cm)	28" (71cm)	36" (91cm)	46" (117cm)	305
DXP5CU	74" (188cm)	28" (71cm)	36" (91cm)	60" (152cm)	345
DXP6CU	88" (224cm)	28" (71cm)	36" (91cm)	74" (188cm)	385

Dimension Additions For Options

- Add 8" to width for cutting board
- Add 12-3/4" to width for solid ribbed tray slide
- Add 12-1/2" to width for 3-bar tray slide

Note: Line-up drawing required when ordering false front, cashier stand or interconnected units.

ITEM NO	DESCRIPTION
DXPPPC	Pizzazz Powder Coating
DXPSCB	8" stainless steel cutting board, flush with top
DXPMCB	8" maple cutting board, flush with top
DXPSRTS	Solid 3-ribbed tray slide, 16-gauge stainless steel
DXP3BTS	3-bar tray slide
DXPMBS	18" maple end bread shelf; left, right - flush with top
DXPSBS	18" stainless steel end bread shelf; left, right - flush with top
DXPCUT	Cut out for drop in dispensers.

ITEM NO	DESCRIPTION
DXPHD	Under storage hinged doors
DXPSD	Under storage sliding doors
DXPRUS	Removable bottom
DXPINT	Intermediate shelf
DXPSKR	Skirting
DXPSSL	Legs in lieu of casters
DXPDOUT	Duplex outlet (120V, 15 AMP)
DXPFRMA	Formica laminate finish without doors

Please confirm that you have the most current specification sheet by visiting www.dinex.com.

It is Dinex's policy to offer equipment which is design certified by companies that have been accredited at the federal level by the Occupational Safety and Health Agency (OSHA) and ANSI as a national recognized testing laboratory. These companies include CSA International, Underwriters Laboratories, Edison Testing Laboratories and National Sanitation Foundation. However, a continuing program of product improvement makes it necessary to submit new models to the agencies as they are developed. Consequently, all models may not bear the appropriate labels at all times.

Dinex reserves the right to change specifications and product design without notice. Such revisions do not entitle the buyer to corresponding changes, improvements, additions or replacements for previously purchased equipment.



DINEX®

4711 E. Hefner Road
Oklahoma City, OK 73131
800.654.8210 | 405.475.5600
www.dinex.com