

## ROLLER & SKATE WHEEL CONVEYORS

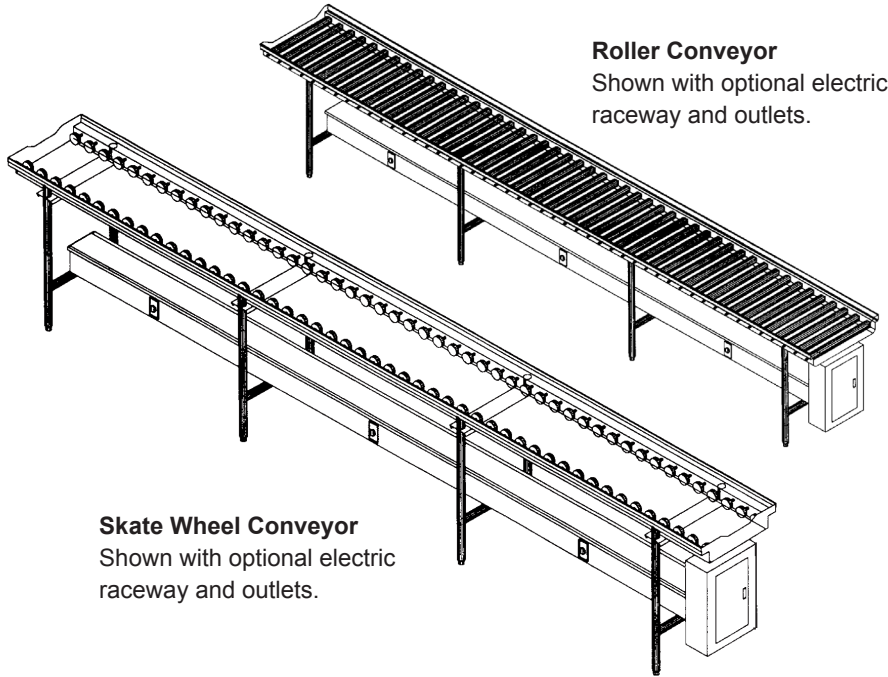

**Roller Conveyor**  
Shown with optional electric raceway and outlets.

**Skate Wheel Conveyor**  
Shown with optional electric raceway and outlets.

### Item Numbers

#### Skate Wheel Conveyors

DXIESSW10  
DXIESSW12  
DXIESSW14  
DXIESSW16  
DXIESSW18  
DXIESSW20

#### Roller Conveyors

DXIESR10  
DXIESR12  
DXIESR14  
DXIESR16  
DXIESR18  
DXIESR20

### Application

The straight-line roller and skate wheel conveyors are designed for tray make-up operations. These conveyors will help streamline tray assembly for any healthcare or catering operation. These units can be equipped with raceways and breaker panels for on-line support equipment connections. Mobile or stationary, these units are designed for easy cleaning and long life. Since these units are built to customer specification some units may not be available in mobile configuration. Please consult factory.

### Construction

Skate wheel assemblies are 2" (5cm) diameter nylon wheels with low friction bushing for free movement. Wheels secured to frame with stainless steel bolts with stainless steel self-locking nuts. Wheels spaced on 3" (8cm) - 4" (10cm) centers removable for cleaning.

Rollers are 1.875" (5cm) O.D. grey PVC tubing with stainless steel ball bearings. Rollers mounted on stainless steel hex spring loaded shafts. The Roller conveyor will handle compartmental or divided trays as well as flat bottom trays.

Conveyor is supported by 1.625" (4cm) O.D. 16-gauge stainless steel tubular legs. Stainless steel tubing to fit into stainless steel sleeves welded to conveyor frame. Legs secured to sleeves with allen head set screws.

Stationary conveyors are provided with stainless steel bullet feet.

For both type conveyors, tray size must be known when unit is ordered to provide proper size cross member and end plates to accommodate tray.

### Options

- Electric raceway
- Outlets
- Casters
- Field joint
- Movable over shelf

**Note:** Engineering data chart must be completed accurately for proper selection of receptacles and panel box.

### Warranty

One year parts and labor.

# ROLLER & SKATE WHEEL CONVEYORS

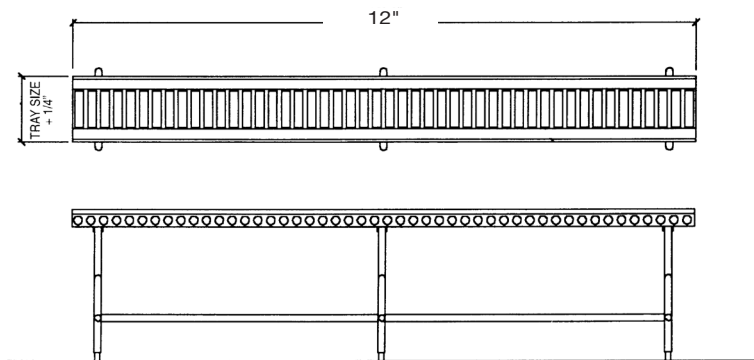

**Roller Conveyor**

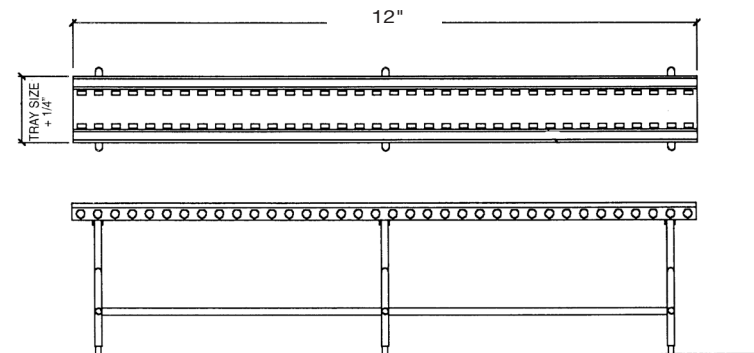

**Skate Wheel Conveyor**

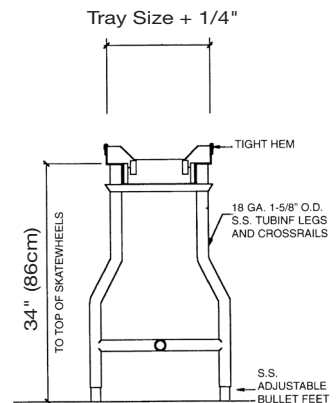
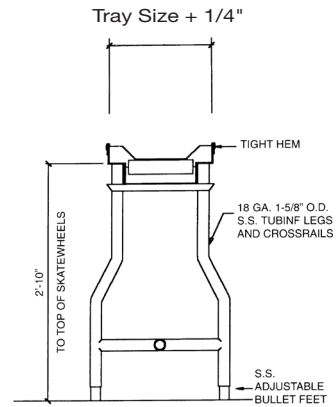

## Items and Dimensions - Skate Wheel Conveyors

ITEM NUMBER	MODEL NUMBER	SIZE	SHIP WEIGHT
DXIESSW10	IESSW10	10 ft. (3.05 meter) section	200 lb. (91kg)
DXIESSW12	IESSW12	12 ft. (3.6 meter) section	240 lb. (109kg)
DXIESSW14	IESSW14	14 ft. (4.3 meter) section	280 lb. (127kg)
DXIESSW16	IESSW16	16 ft. (4.9 meter) section	320 lb. (145kg)
DXIESSW18	IESSW18	18 ft. (5.5 meter) section	360 lb. (163kg)
DXIESSW20	IESSW20	20 ft. (6.1 meter) section	400 lb. (181kg)

## Items and Dimensions - Roller Conveyors

ITEM NUMBER	MODEL NUMBER	SIZE	SHIP WEIGHT
DXIESR10	IESR10	10 ft. (3.05 meter) section	200 lb. (91kg)
DXIESR12	IESR12	12 ft. (3.6 meter) section	240 lb. (109kg)
DXIESR14	IESR14	14 ft. (4.3 meter) section	280 lb. (127kg)
DXIESR16	IESR16	16 ft. (4.9 meter) section	320 lb. (145kg)
DXIESR18	IESR18	18 ft. (5.5 meter) section	360 lb. (163kg)
DXIESR20	IESR20	20 ft. (6.1 meter) section	400 lb. (181kg)

**DINEX**

4711 E. Hefner Road  
 Oklahoma City, OK 73131  
 800.654.8210 | 405.475.5600  
 www.dinex.com

Please confirm that you have the most current specification sheet by visiting [www.dinex.com](http://www.dinex.com).  
 Dinex® reserves the right to change specifications and product design without notice.  
 Such revisions do not entitle the buyer to corresponding changes, improvements,  
 additions or replacements for previously purchased equipment.