

STARTER STATION – STRADDLE STYLE

Compliant with
NSF/ANSI Standard 2



DXPISS60

Item Numbers

DXPISS60

DXPISS72

Application

The Dinex Starter Station (straddle style) will improve your tray line efficiency. This versatile style of starter station is designed to straddle the tray line freeing up valuable space. Dinex offer this style in two sizes, 60" and 72" long.

Durable plastic bins hook onto the lower frame to hold and dispense condiments and silverware. A solid upper shelf holds other tray line material.

- ISSS60 model includes 7 bins and dividers.
- ISSS72 model includes 8 bins and dividers.

Construction

- Frame is constructed of 1" (10cm) square 16-gauge stainless steel tubing.
- Top shelf is constructed of 18-gauge stainless steel.
- Four 5" (12cm) swivel casters 2-with brakes.

Warranty

One year parts and labor.

*We do not accept returns on any Dinex equipment or Dinex custom products.
Please contact your local Dinex rep to ensure order accuracy prior to ordering.*

DINEX®

4711 E. Hefner Road
Oklahoma City, OK 73131
800.654.8210 | 405.475.5600
www.dinex.com

STARTER STATION – STRADDLE STYLE

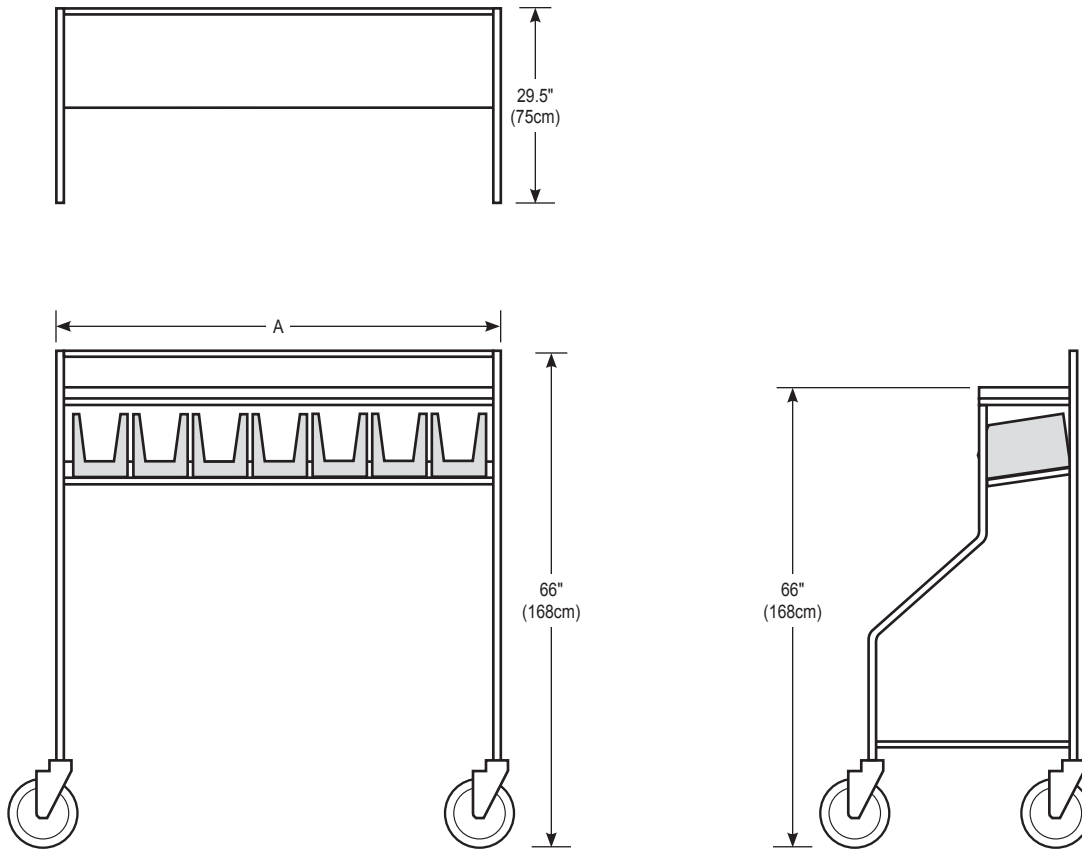

Items and Dimensions

ITEM NUMBER	LENGTH (A)	DEPTH	OVERALL HEIGHT	SHELF HEIGHT	FREIGHT CLASS	SHIP WEIGHT (LBS)
DXPISS60	60" (152cm)	29.5" (75cm)	66" (168cm)	59.5 (151cm)	100	77.6
DXPISS72	72" (183cm)	29.5" (75cm)	66" (168cm)	59.5 (151cm)	100	92.4

Please confirm that you have the most current specification sheet by visiting www.dinex.com.

It is Dinex's policy to offer equipment which is design certified by companies that have been accredited at the federal level by the Occupational Safety and Health Agency (OSHA) and ANSI as a national recognized testing laboratory. These companies include CSA International, Underwriters Laboratories, Edison Testing Laboratories and National Sanitation Foundation. However, a continuing program of product improvement makes it necessary to submit new models to the agencies as they are developed. Consequently, all models may not bear the appropriate labels at all times.

Dinex reserves the right to change specifications and product design without notice. Such revisions do not entitle the buyer to corresponding changes, improvements, additions or replacements for previously purchased equipment.

