

## Thermal•Aire III™ DOCKING STATION



Junior Version

### Item Numbers

#### Junior Docking Station Supports 20 or 24 Capacity Carts

**Air-Cooled Compressor**  
 DXTAIII4782002

**Remote Compressor**  
 DXTAIII4782102

**Water-Cooled Compressor**  
 DXTAIII4782202

#### Senior Docking Station Supports 26 or 30 Capacity Carts

**Air-Cooled Compressor**  
 DXTAIII4782003

**Remote Compressor**  
 DXTAIII4782103

**Water-Cooled Compressor**  
 DXTAIII4782203

### Docking Station Options

- DXISERVVISION i-Serv Vision HACCP Software
- DXTAIII4935002 i-Serv Pack with software and CPU
- DXTAIII4940200 i-Serv Mobile PDA

### Application

Combining state-of-the-art precision air convection, and simultaneous refrigeration, the Thermal•Aire III system design optimizes flexibility and simplicity of operation while enhancing food quality, presentation and the ability to expand menu choices. Designed to be used with the Dinex Thermal•Aire III cart, this electronic docking station can rethermalize up to 30 trays automatically or manually at the touch of a button.

Featuring new controls with an integrated data recording system and alarms to notify staff of meal completion, the Thermal•Aire III docking station has put simplicity back into meal delivery systems. The Thermal•Aire III docking stations are available in two model sizes. The Junior accommodates a 20 or 24 tray cart and the Senior accepts a 26 or 30 tray carts.

### Performance

Retherming chilled food from 37°F (3°C) to 165°F (74°C) in less than one hour while keeping cold food below 40°F (4°C).

### Standard Features

- Integrated electrical and technical components
- Independent hot and cold air generation
- Automatic motorized connection station cart with auto-clasp

- Manual disconnecting device for cart/docking station in case of extended power cut
- Docking Station on casters for easier maintenance and installation
- New electronics and integrated data recording and preventive maintenance system
- Count down timer display and end of cycle alarm
- Temperature display in both hot and cold chambers
- Automatic change for daylight savings
- Auto diagnostic with indicator lights
- Stainless steel frame
- Thermoformed ABS front and side panels
- Cart Locking system
- Locking swivel casters (5" diam.)
- Removable gaskets without tools
- Cart disconnecting button
- Pivoting top panel for easier access to technical components
- Digital control panel with i-Serv Programmer Technology:
  - Cold / hot chamber temperatures
  - Retherm count down timer
  - Illuminated color status indicator
  - Timer

- Stop button
- Programming keys
- Maintenance history and active status
- Five (5) programmable meals (4 regular / 1 boost)
- Temperature history

### Options

- Self-contained air-cooled, water-cooled or remote condensing unit refrigeration
- i-Serv computer software and mobile pda for temperature recording and programming.

### Warranty

One year parts and labor.

***We do not accept returns on any Dinex equipment or Dinex custom products. Please contact your local Dinex rep to ensure order accuracy prior to ordering.***

# Thermal•Aire III™ DOCKING STATION

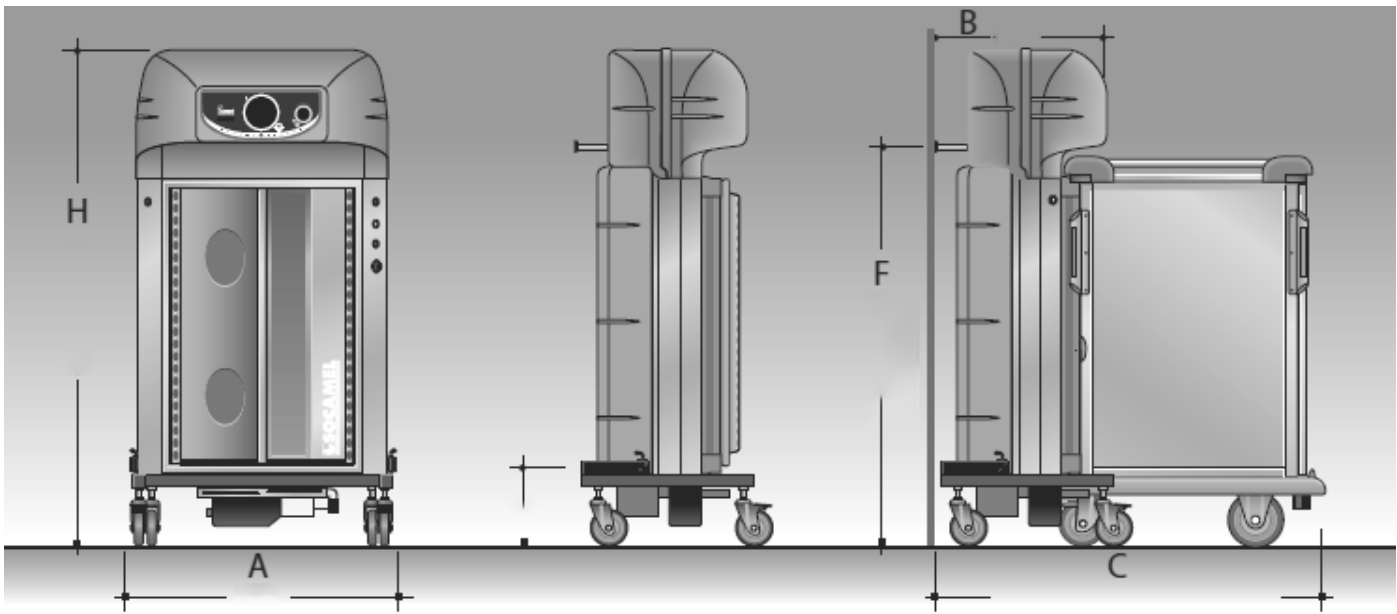

DOCKING STATION	VOLTAGE	POWER	PHASE 1 / PHASE 2 / PHASE 3	LOAD
Junior Docking Station	208V / 3PH / 60Hz	7940W	16.6A / 24.6A / 24.6A	30 AMPS / 4 -wire
Senior Docking Station	208V / 3PH / 60Hz	9270W	26.6A / 27.6A / 27.6A	30 AMPS / 4 -wire

## Items and Dimensions

ITEM NUMBER	DESCRIPTION	WIDTH A	DEPTH B	DEPTH WITH CART C	HEIGHT	SHIP WEIGHT
DXTAIII4782002	Junior Docking Station Air-Cooled Compressor	35.6" (90cm)	22.8" (58.0cm)	53.5" (136.0cm)	68.7" (174.5cm)	347 lb (152kg)
DXTAIII4782003	Senior Docking Station Air-Cooled Compressor	35.6" (90cm)	22.8" (58.0cm)	53.5" (136.0cm)	78.0" (198.0cm)	381 lb (163kg)
DXTAIII4782102	Junior Docking Station Remote Compressor	35.6" (90cm)	22.8" (58.0cm)	53.5" (136.0cm)	68.7" (174.5cm)	347 lb (152kg)
DXTAIII4782103	Senior Docking Station Remote Compressor	35.6" (90cm)	22.8" (58.0cm)	53.5" (136.0cm)	78.0" (198.0cm)	381 lb (163kg)
DXTAIII4782202	Junior Docking Station Water-Cooled Compressor	35.6" (90cm)	22.8" (58.0cm)	53.5" (136.0cm)	68.7" (174.5cm)	347 lb (152kg)
DXTAIII4782203	Senior Docking Station Water-Cooled Compressor	35.6" (90cm)	22.8" (58.0cm)	53.5" (136.0cm)	78.0" (198.0cm)	381 lb (163kg)

## Operating Requirements

- Allow 12" space between each station and/or other device for repairs
- Keep station away from any radiant heat source
- The station should be located in a well ventilated room
- Install the station in a room where the ceiling height is at least 8'
- The ambient temperature should not exceed 89°F (32°C)
- Do not block condenser air flow at top of docking station.

## Cleaning

- Clean with a wet sponge with non-caustic sanitizing solution
- Hand dry the docking station

Please confirm that you have the most current specification sheet by visiting [www.dinex.com](http://www.dinex.com). Dinex® reserves the right to change specifications and product design without notice. Such revisions do not entitle the buyer to corresponding changes, improvements, additions or replacements for previously purchased equipment.

**DINEX**  
A CARLISLE COMPANY

4711 E Hefner Road  
Oklahoma City, OK 73131  
800.654.8210 • 405.475.5600  
[www.dinex.com](http://www.dinex.com)