

## DINEXPRESS SLIMLINE COLD FOOD COUNTERS – MECHANICALLY OR ICE REFRIGERATED

Compliant with  
NSF/ANSI Standard 2

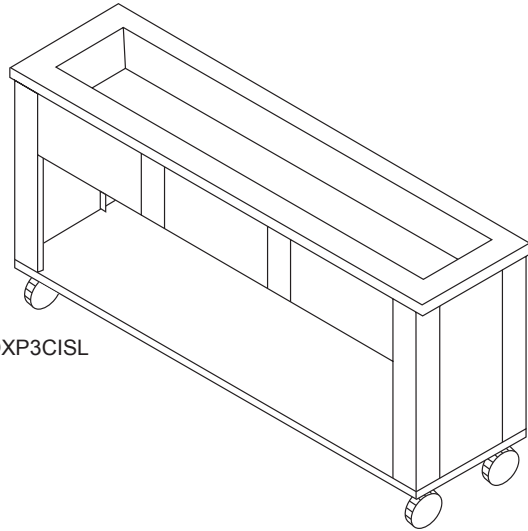

DXP3CISL

### Item Numbers

Mechanically Cooled  
DXP2CMSL  
DXP3CMSL

Ice Cooled  
DXP2CISL  
DXP3CISL

The DineXpress Slimline Cold unit is available mechanically cooled (CMSL) or ice only (CISL). The versatile modular design allows you to customize your tray make-up line, choosing only the options and accessories that you want and need.

### Standard Features

- 14-gauge stainless steel top with 1-1/2" turndown on all sides
- Top secured by four recessed bolts for easy access
- Framing includes 14-gauge top fastened to 14-gauge corner posts fastened to 14-gauge caster channels fastened to 18-gauge stainless steel bottom shelf, open control side
- 20-gauge stainless steel end and front panels are attached to legs
- 20-gauge stainless steel fully welded 5" deep well with drain
- Well is enclosed with insulation on sides, end and bottom
- 1" drain with shut off valve shall exit operator's left side as standard. Drain valve is 3/4" FPT.
- Open control side for additional storage capacity on Elite units

- Sliding doors standard on Mechanical (CMSL) units only
- Louvered panels for ventilation of condensing unit on CMSL units
- End louver panel removable to access compressor on CMSL units
- 5" diameter swivel plate casters, 2 with brakes

### Dimensions

DXP2CMSL – 36"H x 19"D x 50"L

DXP3CMSL – 36"H x 19"D x 72"L

DXP2CISL – 36"H x 19"D x 50"L

3-CISL - 36"H x 19"D x 72"L

36" height on all standard units

19" width

50" to 72" length in 22" increments

### Electrical – CM Units Only

- 120 volts single-phase
- Eight foot electrical cord with NEMA 5-15P plug
- On/Off switch and pilot light mounted on control panel of unit's operator side

### Refrigeration System – CM Units Only

- 1/3 horsepower compressor
- Fan-cooled condensing unit with an expansion valve pressure control switch
- Refrigerant coils shall be of copper tubing attached to the bottom of the well

### Common Options

- Pizzazz powder coating in lieu of stainless steel
- Tray slides
- Protector guards
- Hinged or sliding doors on CI units
- See reverse side for additional options

### Warranty

One year parts and labor.

# DINEXPRESS SLIMLINE COLD FOOD COUNTERS – MECHANICALLY OR ICE REFRIGERATED

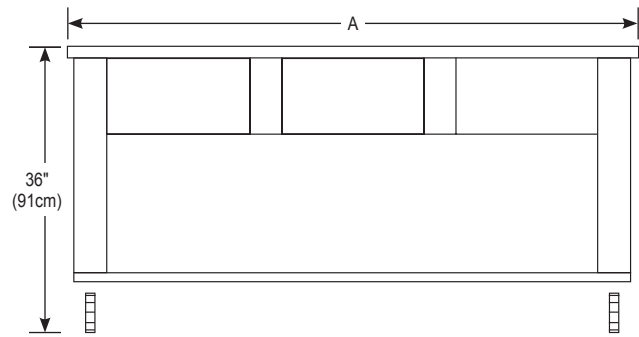
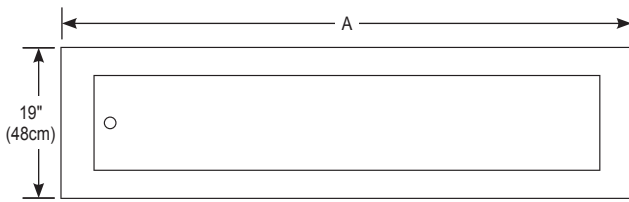

## Items and Dimensions

| ITEM NUMBER | 12" X 20" PAN CAPACITY* | LENGTH (A)  | WIDTH      | HEIGHT     | AMPS (120V) | NEMA CAP NUMBER (120V) | SHIP WEIGHT (LBS) |
|-------------|-------------------------|-------------|------------|------------|-------------|------------------------|-------------------|
| DXP2CM      | 2                       | 50" (127cm) | 19" (48cm) | 36" (91cm) | 6.3         | 5-15P                  | 225               |
| DXP3CM      | 3                       | 72" (183cm) | 19" (48cm) | 36" (91cm) | 6.3         | 5-15P                  | 265               |

## Dimension Additions For Options

- Add 8" to width for cutting board
- Add 12-3/4" to width for solid ribbed tray slide
- Add 12-1/2" to width for 3-bar tray slide

Note: Line-up drawing required when ordering false front, cashier stand or interconnected units.

\*Amperage/NEMA plug type may vary with options.

| ITEM NO  | DESCRIPTION   |
|----------|---|
| DXPPPC   | PIZZAZZ POWDER COATING                                      |
| DXPSCB   | 8" stainless steel cutting board, flush with top            |
| DXPMCB   | 8" maple cutting board, flush with top                      |
| DXPSRTS  | Solid 3-ribbed tray slide, 16-gauge stainless steel         |
| DXP3BTS  | 3-bar tray slide, 34" height                                |
| DXPHD/SD | Hinged or sliding doors on Ice (CI) unit                    |
| DXPFRMAD | Formica laminate finish with doors                          |
| DXPOHS   | Overhead shelf less plexiglass                              |
| DXPSSL   | Legs in lieu of casters                                     |
| DXPDOUT  | Duplex outlet (120V, 15 AMP)                                |
| DXPFB    | False bottom  |
| DXPFPB   | Full Perimeter Bumper                                       |
| DXPCP    | Correctional package  |
| DXPCDD   | Cafeteria double display (no heat or lights)                |
| DXPCDDL  | Cafeteria double display with fluorescent lights            |
| DXPBP1   | Buffet single side protector guard (no heat or lights)      |
| DXPBP1IL | Buffet single side protector guard with incandescent lights |
| DXPBP1FL | Buffet single side protector guard with fluorescent lights  |
| DXPBP2   | Buffet double side protector guard (no heat or lights)      |

| ITEM NO   | DESCRIPTION  |
|-----------|--|
| DXPBP2GIL | Buffet double side protector guard with incandescent lights                |
| DXPBP2GFL | Buffet double side protector guard with fluorescent lights                 |
| DXPBEG    | Buffet end guards, right or left   |
| DXPBDD    | Buffet double display two-sided protector guard                            |
| DXPBP2GC  | Classic protector guards   |
| DXPCDDC   | Cafeteria Style Classic Double Display protector guards                    |
| DXPBP2G1C | Buffet style classic single sided protector guard                          |
| DXPSP2GC  | Cafeteria style classic single protector guards                            |
| DXPSSL    | Legs in lieu of casters  |
| DXPDOUT   | Duplex outlet (120v, 15 amp)   |
| DXPFB     | False bottom   |
| DXPSBT    | Stainless steel salad bar template.  |
| DXPUCR-1  | Refrigerated storage base with doors and pan slides on units 60" or longer |
| DXPUCR-2  | Refrigerated storage base with doors and pan slides on units 74" or longer |
| DXPSKR    | Skirting   |
| DXPFF     | Fill faucet  |
| DXPSKR    | Skirting   |

Please confirm that you have the most current specification sheet by visiting [www.dinex.com](http://www.dinex.com).

It is Dinex's policy to offer equipment which is design certified by companies that have been accredited at the federal level by the Occupational Safety and Health Agency (OSHA) and ANSI as a national recognized testing laboratory. These companies include CSA International, Underwriters Laboratories, Edison Testing Laboratories and National Sanitation Foundation. However, a continuing program of product improvement makes it necessary to submit new models to the agencies as they are developed. Consequently, all models may not bear the appropriate labels at all times.

Dinex reserves the right to change specifications and product design without notice. Such revisions do not entitle the buyer to corresponding changes, improvements, additions or replacements for previously purchased equipment.



# DINEX®

4711 E. Hefner Road  
Oklahoma City, OK 73131  
800.654.8210 | 405.475.5600  
[www.dinex.com](http://www.dinex.com)