

TOTALLY QUIET (TQ) COMPACT TRAY DELIVERY CARTS SINGLE DOOR WITH ONE TRAY PER SLIDE

Compliant with
NSF/ANSI Standard 2

Item Numbers

DXPTQC1T1D8



DXPTQC1T1D8

Application

TQ Compact Carts offer you a cart that has a notable sound dampening construction where quiet is a needed commodity.

This equipment is intended for "Industrial Use Only".

Construction

TQ Compact Cart is a single door tray delivery cart with an all stainless steel modular construction. The cart has (standard) 4-3/4" tray height spacing (additional tray spacings are available - consult factory for availability) with 1 tray per shelf for a total of 8 tray capacity. Comes with heat release vented side panels and standard corner bumpers. The cart has gravity locking doors with noise suppression door bumpers and gravity locking (open) door with door stop for noise reduction. The cart comes with an interchangeable rack system with adjustable sizing to accommodate for

different tray sizes. The racks also have noise reduction gravity locking brackets with a press lever release mechanism. The side panels of the cart have a noise reduction channel to prevent vibration while the cart is in motion.

Casters

The cart comes with 6" Performa casters with noise suppression bearing covers, high temperature wash resistant noise dampening bearing grease and caster isolation pads (2 rigid, 2 swivel with Tech lock brakes).

Standard Features

- 6" Performa casters with noise suppression bearing covers (2 rigid, 2 swivel with Tech lock brakes)
- Corner bumpers
- Vertical push handles
- Gravity locking doors with door stop
- Full length door handles

- 4-3/4" tray height spacing

Compatible Tray Sizes

- 12" x 19"
- 12" x 20"
- 14" x 18"
- 15" x 20"
- DXRST152003

Warranty

One year parts and labor.

**We do not accept returns on any Dinex equipment or Dinex custom products.
Please contact your local Dinex rep to ensure order accuracy prior to ordering.**

DINEX®

4711 E. Hefner Road
Oklahoma City, OK 73131
800.654.8210 | 405.475.5600
www.dinex.com

Rev 09/20

TOTALLY QUIET (TQ) COMPACT TRAY DELIVERY CARTS SINGLE DOOR WITH ONE TRAY PER SLIDE

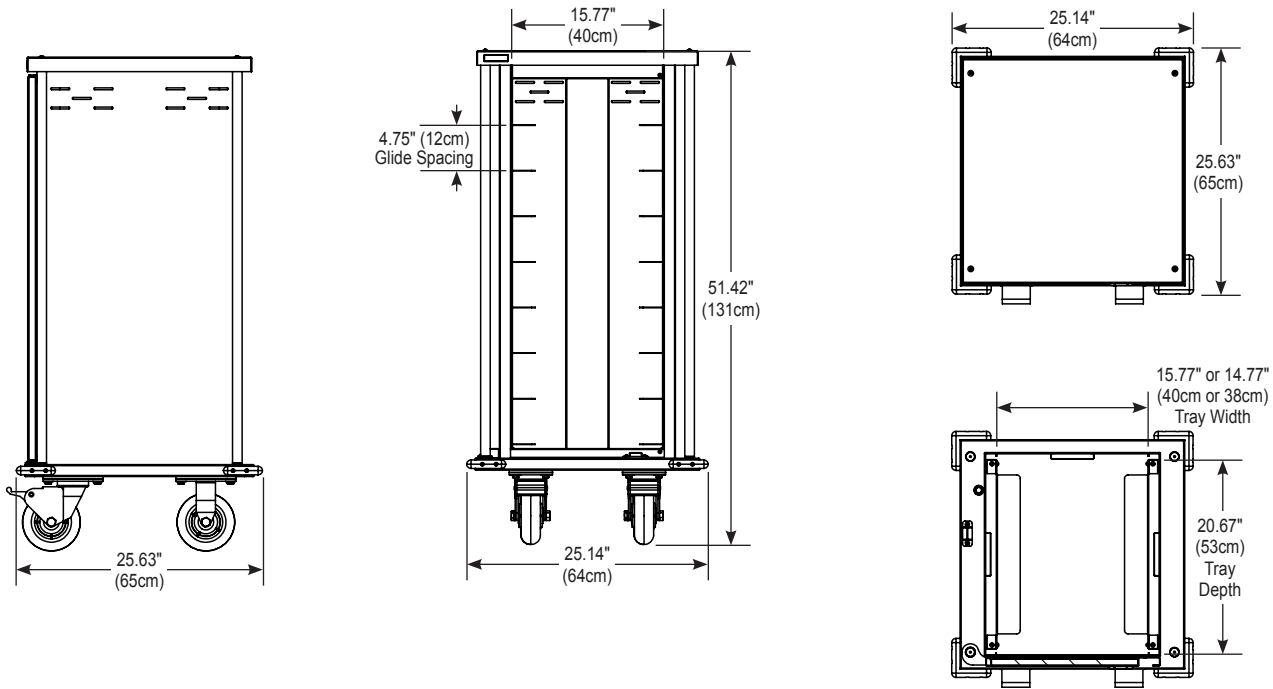

Items and Dimensions

ITEM NUMBER	WIDTH*	DEPTH*	HEIGHT	CASTERS		SHIP CUBE	TRAY SPACING	CART WEIGHT	TRAY CAPACITY
				TYPE	DIAMETER				
DXPTQC1T1D8	25.14" (64cm)	25.63" (65cm)	51.42" (131cm)	2 rigid, 2 swivel w/Tech lock brakes	6" (15cm)	254 lb (115kg)	4.75" (12cm)	120 lbs (54kg)	8

* Wrap around bumper option adds 2" (5cm) to the overall length and depth

All carts are designed for the following tray sizes:
12" x 19", 12" x 20", 14" x 18", 15" x 20", DXRST152003

Standard Options Available

- 3 & 4 Sided Top Rails
- Menu Holder
- Floor Drain
- Wrap Around Bumpers*
- Contact your Sales Representative for more information on the available standard options

Please confirm that you have the most current specification sheet by visiting www.dinex.com.

It is Dinex's policy to offer equipment which is design certified by companies that have been accredited at the federal level by the Occupational Safety and Health Agency (OSHA) and ANSI as a national recognized testing laboratory. These companies include CSA International, Underwriters Laboratories, Edison Testing Laboratories and National Sanitation Foundation. However, a continuing program of product improvement makes it necessary to submit new models to the agencies as they are developed. Consequently, all models may not bear the appropriate labels at all times.

Dinex reserves the right to change specifications and product design without notice. Such revisions do not entitle the buyer to corresponding changes, improvements, additions or replacements for previously purchased equipment.



TOTALLY QUIET (TQ) COMPACT TRAY DELIVERY CARTS DOUBLE DOOR WITH ONE TRAY PER SLIDE

Compliant with
NSF/ANSI Standard 2



DXPTQC1T2D16

Item Numbers

DXPTQC1T2D10
DXPTQC1T2D12
DXPTQC1T2D14
DXPTQC1T2D16
DXPTQC1T2D18
DXPTQC1T2D20

Application

TQ Compact Carts offer you a cart that has a notable sound dampening construction where quiet is a needed commodity.

This equipment is intended for "Industrial Use Only".

Construction

TQ Compact Cart is a double door tray delivery cart with an all stainless steel modular construction. The cart has (standard) 4-3/4" tray height spacing with 1 tray per shelf for a total of 10, 12, 14, 16, 18 and or 20 capacity. Comes with heat release vented side panels and standard corner bumpers. The cart has gravity locking doors with noise suppression door bumpers and gravity locking (open) door with door stop for noise reduction. The cart comes with an interchangeable rack system with adjustable sizing to accommodate for

different tray sizes. The racks also have noise reduction gravity locking brackets with a press lever release mechanism. The side panels of the cart have a noise reduction channel to prevent vibration while the cart is in motion. The cart comes with 6" Performa casters with noise suppression bearing covers, high temperature wash resistant noise dampening bearing grease, and caster isolation pads.

Standard Features

- 6" Performa casters with noise suppression bearing covers
- Corner Bumpers
- Vertical Push Handles
- Gravity Locking Doors with Door Stop
- Full Length Door Handles
- 4-3/4" tray height spacing

Compatible Tray Sizes

- 12" x 19"
- 12" x 20"
- 14" x 18"
- 15" x 20"
- DXRST152003

Warranty

One year parts and labor.

*We do not accept returns on any Dinex equipment or Dinex custom products.
Please contact your local Dinex rep to ensure order accuracy prior to ordering.*

DINEX®

4711 E. Hefner Road
Oklahoma City, OK 73131
800.654.8210 | 405.475.5600
www.dinex.com

Rev 09/20

TOTALLY QUIET (TQ) COMPACT TRAY DELIVERY CARTS DOUBLE DOOR WITH ONE TRAY PER SLIDE

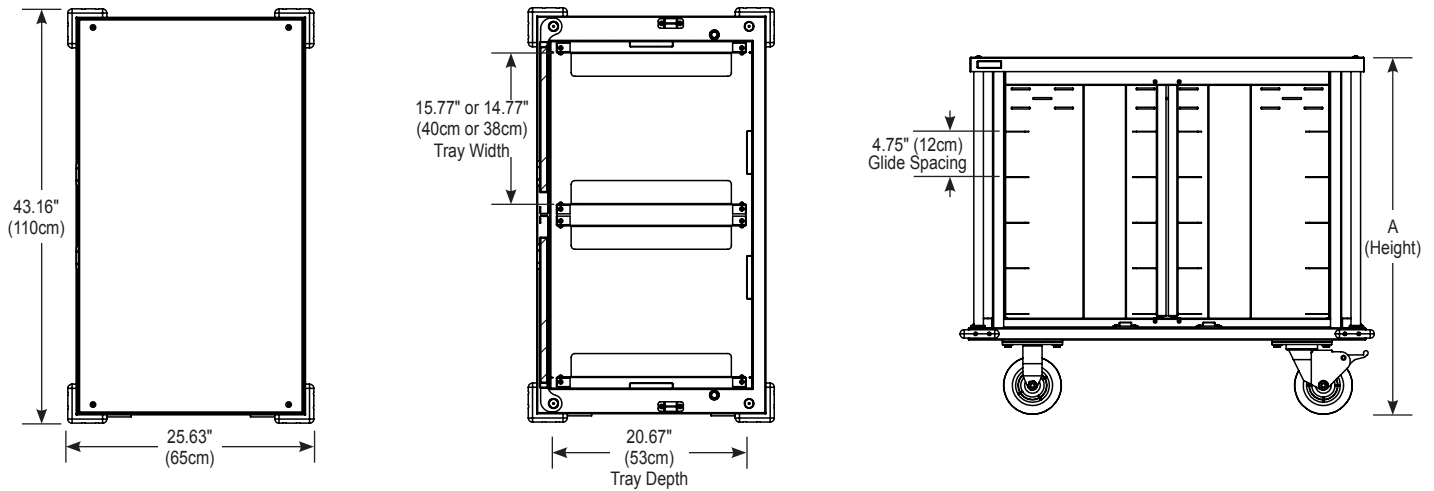

Items and Dimensions

ITEM NUMBER	WIDTH*	DEPTH*	HEIGHT (A)	CASTERS		TRAY SPACING	TRAY CAPACITY	CART WEIGHT	SHIP WEIGHT
				TYPE	DIAMETER				
DXPTQC1T2D10	43.16" (110cm)	25.63" (65cm)	37.17" (17cm)	2 rigid, 2 swivel w/Tech lock brakes	6" (15cm)	4.75" (12cm)	10	144 lbs (65kg)	331 lbs (150kg)
DXPTQC1T2D12	43.16" (110cm)	25.63" (65cm)	41.92" (19cm)	2 rigid, 2 swivel w/Tech lock brakes	6" (15cm)	4.75" (12cm)	12	162 lbs (73kg)	290 lbs (132kg)
DXPTQC1T2D14	43.16" (110cm)	25.63" (65cm)	46.67" (21cm)	2 rigid, 2 swivel w/Tech lock brakes	6" (15cm)	4.75" (12cm)	14	180 lbs (83kg)	359 lbs (163kg)
DXPTQC1T2D16	43.16" (110cm)	25.63" (65cm)	51.42" (23cm)	2 rigid, 2 swivel w/Tech lock brakes	6" (15cm)	4.75" (12cm)	16	198 lbs (90kg)	455 lbs (206kg)
DXPTQC1T2D18	43.16" (110cm)	25.63" (65cm)	56.17" (25cm)	2 rigid, 2 swivel w/Tech lock brakes	6" (15cm)	4.75" (12cm)	18	216 lbs (98kg)	387 lbs (176kg)
DXPTQC1T2D20	43.16" (110cm)	25.63" (65cm)	60.92" (28cm)	2 rigid, 2 swivel w/Tech lock brakes	6" (15cm)	4.75" (12cm)	20	234 lbs (106kg)	300 lbs (136kg)

* Wrap around bumper option adds 2" (5cm) to the overall length and depth

All carts are designed for the following tray sizes:

12" x 19", 12" x 20", 14" x 18", 15" x 20", DXRST152003

Standard Options Available

- 3 & 4 Sided Top Rails
- Menu Holder
- Floor Drain
- Multiple caster options

• Wrap Around Bumpers*

- Contact your Sales Representative for more information on the available standard options

Please confirm that you have the most current specification sheet by visiting www.dinex.com.

It is Dinex's policy to offer equipment which is design certified by companies that have been accredited at the federal level by the Occupational Safety and Health Agency (OSHA) and ANSI as a national recognized testing laboratory. These companies include CSA International, Underwriters Laboratories, Edison Testing Laboratories and National Sanitation Foundation. However, a continuing program of product improvement makes it necessary to submit new models to the agencies as they are developed. Consequently, all models may not bear the appropriate labels at all times.

Dinex reserves the right to change specifications and product design without notice. Such revisions do not entitle the buyer to corresponding changes, improvements, additions or replacements for previously purchased equipment.



TOTALLY QUIET (TQ) COMPACT TRAY DELIVERY CARTS – SINGLE DOOR WITH TWO TRAYS PER SLIDE

Compliant with
NSF/ANSI Standard 2



DXPTQC2T1DPT12

Item Numbers

DXPTQC2T1D10
DXPTQC2T1D12
DXPTQC2T1D14
DXPTQC2T1D16
DXPTQC2T1D18
DXPTQC2T1D20

Pass Thru Model

DXPTQC2T1DPT10
DXPTQC2T1DPT12
DXPTQC2T1DPT14
DXPTQC2T1DPT16
DXPTQC2T1DPT18
DXPTQC2T1DPT20

Application

TQ Compact Carts offer you a cart that has a notable sound dampening construction where quiet is a needed commodity.

This equipment is intended for "Industrial Use Only".

Construction

TQ Compact Cart is a single door tray delivery cart with an all stainless steel modular construction. The cart has (standard) 4-3/4" tray height spacing (additional tray spacings are available - consult factory for availability) with 2 trays per shelf for a total of 10, 12, 14, 16, 18 and or 20 tray capacity. Comes with heat release vented side panels and standard corner bumpers. The cart has gravity locking doors with noise suppression door bumpers and gravity locking (open) door with door stop for noise reduction. The cart

comes with an interchangeable rack system with adjustable sizing to accommodate for different tray sizes. The racks also have noise reduction gravity locking brackets with a press lever release mechanism. The side panels of the cart have a noise reduction channel to prevent vibration while the cart is in motion.

Casters

The cart comes with 6" Performa casters with noise suppression bearing covers, high temperature wash resistant noise dampening bearing grease, and caster isolation pads (2 rigid, 2 swivel with Tech lock brakes).

Standard Features

- 6" Performa casters with noise suppression bearing covers (2 rigid, 2 swivel with Tech lock brakes)
- Corner Bumpers
- Vertical Push Handles
- Gravity Locking Doors with Door Stop
- Full Length Door Handles
- 4-3/4" tray height spacing

Compatible Tray Sizes

- 12" x 19"
- 12" x 20"
- 14" x 18"
- 15" x 20"
- DXRST152003

Warranty

One year parts and labor.

DINEX®

4711 E. Hefner Road
Oklahoma City, OK 73131
800.654.8210 | 405.475.5600
www.dinex.com

*We do not accept returns on any Dinex equipment or Dinex custom products.
Please contact your local Dinex rep to ensure order accuracy prior to ordering.*

TOTALLY QUIET (TQ) COMPACT TRAY DELIVERY CARTS – SINGLE DOOR WITH TWO TRAYS PER SLIDE

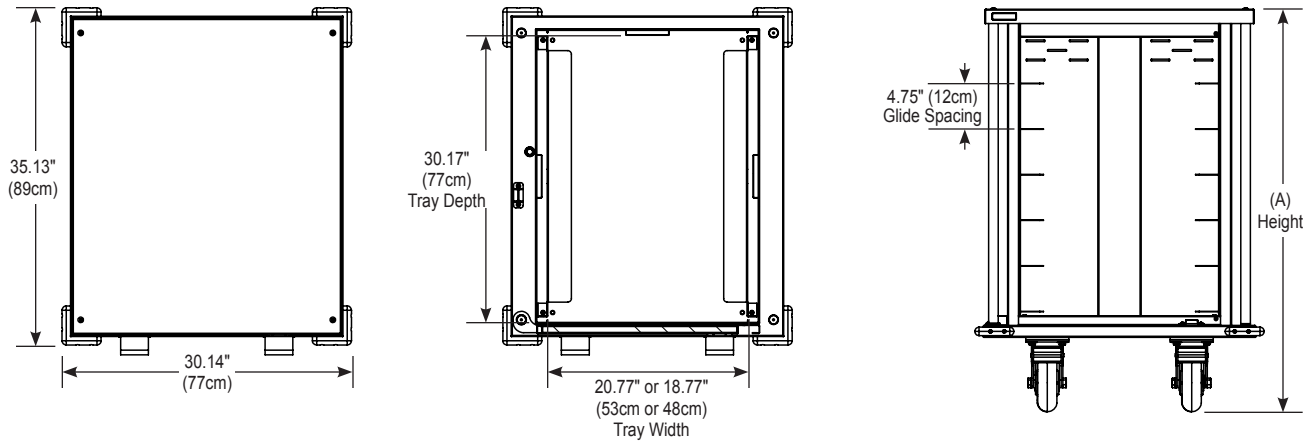

Items and Dimensions

ITEM NUMBER	WIDTH*	DEPTH*	HEIGHT (A)	CASTERS		TRAY SPACING	TRAY CAPACITY	CART WEIGHT	SHIP WEIGHT
				TYPE	DIAMETER				
DXPTQC2T1D10 DXPTQC2T1DPT10	30.14" (77cm)	35.13" (89cm)	37.17" (94cm)	2 rigid, 2 swivel w/Tech lock brakes	6" (15cm)	4.75" (12cm)	10	141 lbs (64kg)	288 lbs (131kg)
DXPTQC2T1D12 DXPTQC2T1DPT12	30.14" (77cm)	35.13" (89cm)	41.92" (106cm)	2 rigid, 2 swivel w/Tech lock brakes	6" (15cm)	4.75" (12cm)	12	159 lbs (72kg)	308 lbs (140kg)
DXPTQC2T1D14 DXPTQC2T1DPT14	30.14" (77cm)	35.13" (89cm)	46.67" (119cm)	2 rigid, 2 swivel w/Tech lock brakes	6" (15cm)	4.75" (12cm)	14	176 lbs (80kg)	310 lbs (141kg)
DXPTQC2T1D16 DXPTQC2T1DPT16	30.14" (77cm)	35.13" (89cm)	51.42" (131cm)	2 rigid, 2 swivel w/Tech lock brakes	6" (15cm)	4.75" (12cm)	16	194 lbs (88kg)	451 lbs (205kg)
DXPTQC2T1D18 DXPTQC2T1DPT18	30.14" (77cm)	35.13" (89cm)	56.17" (143cm)	2 rigid, 2 swivel w/Tech lock brakes	6" (15cm)	4.75" (12cm)	18	211 lbs (96kg)	375 lbs (170kg)
DXPTQC2T1D20 DXPTQC2T1DPT20	30.14" (77cm)	35.13" (89cm)	60.92" (155cm)	2 rigid, 2 swivel w/Tech lock brakes	6" (15cm)	4.75" (12cm)	20	228 lbs (103kg)	350 lbs (159kg)

* Wrap around bumper option adds 2" (5cm) to the overall length and depth

All carts are designed for the following tray sizes:
12" x 19", 12" x 20", 14" x 18", 15" x 20", DXRST152003

Standard Options Available

- 3 & 4 Sided Top Rails
- Menu Holder
- Floor Drain
- Multiple caster options
- Wrap Around Bumpers*
- Contact your Sales Representative for more information on the available standard options

Please confirm that you have the most current specification sheet by visiting www.dinex.com.

It is Dinex's policy to offer equipment which is design certified by companies that have been accredited at the federal level by the Occupational Safety and Health Agency (OSHA) and ANSI as a national recognized testing laboratory. These companies include CSA International, Underwriters Laboratories, Edison Testing Laboratories and National Sanitation Foundation. However, a continuing program of product improvement makes it necessary to submit new models to the agencies as they are developed. Consequently, all models may not bear the appropriate labels at all times.

Dinex reserves the right to change specifications and product design without notice. Such revisions do not entitle the buyer to corresponding changes, improvements, additions or replacements for previously purchased equipment.



TOTALLY QUIET (TQ) COMPACT CARTS DOUBLE DOOR TRAY DELIVERY CARTS WITH TWO TRAYS PER SLIDE

Compliant with
NSF/ANSI Standard 2

Item Numbers

DXPTQC2T2D20
DXPTQC2T2D24
DXPTQC2T2D28
DXPTQC2T2D32
DXPTQC2T2D36

Pass Thru Model

DXPTQC2T2DPT20
DXPTQC2T2DPT24
DXPTQC2T2DPT28
DXPTQC2T2DPT32
DXPTQC2T2DPT36



DXPTQC2T2D24

Application

TQ Compact Carts offer you a cart that has a notable sound dampening construction where quiet is a needed commodity.

This equipment is intended for "Industrial Use Only"

Construction

TQ Compact Cart double door tray delivery cart with an all stainless steel modular construction. The cart has (standard) 4-3/4" tray height spacing (additional tray spacings are available – consult factory for availability) with 2 trays per shelf for a total of a 24, 28, 32 and or 36 tray capacity. Comes with heat release vented side panels and standard corner bumpers. The cart has gravity locking doors with noise suppression door bumpers and gravity locking (open) door with door stop for noise reduction. The cart comes with an interchangeable rack system with adjustable sizing to accommodate for different tray sizes. The racks also have

noise reduction gravity locking brackets with a press lever release mechanism. The side panels of the cart have a noise reduction channel to prevent vibration while the cart is in motion.

Casters

The cart comes with 6" Performa casters with noise suppression bearing covers, high temperature wash resistant noise dampening bearing grease, and caster isolation pads (2 rigid, 2 swivel with Tech lock brakes).

Standard Features

- 6" Performa casters with noise suppression bearing covers (2 rigid, 2 swivel with Tech lock brakes)
- Corner Bumpers
- Vertical Push Handles
- Gravity Locking Doors with Door Stop
- Full Length Door Handles
- 4-3/4" tray height spacing

Compatible Tray Sizes

- 12" x 19"
- 12" x 20"
- 14" x 18"
- 15" x 20"
- DXRST152003

Warranty

One year parts and labor.

*We do not accept returns on any Dinex equipment or Dinex custom products.
Please contact your local Dinex rep to ensure order accuracy prior to ordering.*

DINEX®

4711 E. Hefner Road
Oklahoma City, OK 73131
800.654.8210 | 405.475.5600
www.dinex.com

Rev 09/20

TOTALLY QUIET (TQ) COMPACT CARTS

DOUBLE DOOR TRAY DELIVERY CARTS WITH TWO TRAYS PER SLIDE

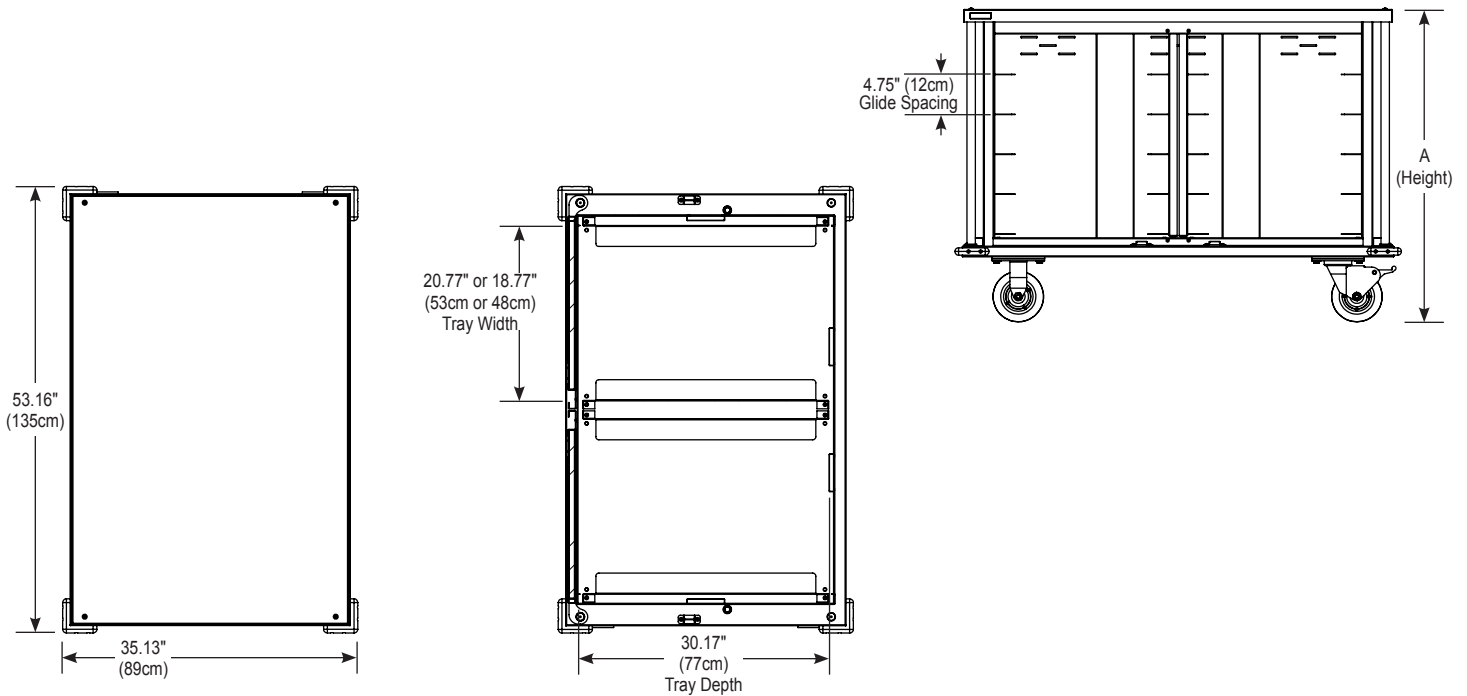

Items and Dimensions

ITEM NUMBER	WIDTH*	DEPTH*	HEIGHT (A)	CASTERS		TRAY SPACING	TRAY CAPACITY	CART WEIGHT	SHIP WEIGHT
				TYPE	DIAMETER				
DXPTQC2T2D20 DXPTQC2T2DPT20	53.16" (135cm)	35.13" (89cm)	37.17" (94cm)	2 rigid, 2 swivel w/ Tech lock brakes	6" (15cm)	4.75" (12cm)	20	235 lbs (107kg)	451 lbs (205kg)
DXPTQC2T2D24 DXPTQC2T2DPT24	53.16" (135cm)	35.13" (89cm)	41.92" (106cm)	2 rigid, 2 swivel w/ Tech lock brakes	6" (15cm)	4.75" (12cm)	24	265 lbs (120kg)	487 lbs (221kg)
DXPTQC2T2D28 DXPTQC2T2DPT28	53.16" (135cm)	35.13" (89cm)	46.67" (119cm)	2 rigid, 2 swivel w/ Tech lock brakes	6" (15cm)	4.75" (12cm)	28	295 lbs (134kg)	487 lbs (221kg)
DXPTQC2T2D32 DXPTQC2T2DPT32	53.16" (135cm)	35.13" (89cm)	51.42" (131cm)	2 rigid, 2 swivel w/ Tech lock brakes	6" (15cm)	4.75" (12cm)	32	325 lbs (147kg)	523 lbs (237kg)
DXPTQC2T2D36 DXPTQC2T2DPT36	53.16" (135cm)	35.13" (89cm)	56.17" (143cm)	2 rigid, 2 swivel w/ Tech lock brakes	6" (15cm)	4.75" (12cm)	36	355 lbs (161kg)	523 lbs (237kg)

* Wrap around bumper option adds 2" (5cm) to the overall length and depth

All carts are designed for the following tray sizes:

12" x 19", 12" x 20", 14" x 18", 15" x 20", DXRST152003

Standard Options Available

- 3 & 4 Sided Top Rails
- Menu Holder
- Floor Drain
- Wrap Around Bumpers*
- Wall Saver Bumpers
- Tow Hitch
- 5 Caster configuration
- 6 Caster configuration
- Contact your Sales Representative for more information on the available standard options

Please confirm that you have the most current specification sheet by visiting www.dinex.com.

It is Dinex's policy to offer equipment which is design certified by companies that have been accredited at the federal level by the Occupational Safety and Health Agency (OSHA) and ANSI as a national recognized testing laboratory. These companies include CSA International, Underwriters Laboratories, Edison Testing Laboratories and National Sanitation Foundation. However, a continuing program of product improvement makes it necessary to submit new models to the agencies as they are developed. Consequently, all models may not bear the appropriate labels at all times.

Dinex reserves the right to change specifications and product design without notice. Such revisions do not entitle the buyer to corresponding changes, improvements, additions or replacements for previously purchased equipment.

