

Hot Food Counters Service Manual

**Models DVLHF/2, DVLHFSL/2,
DVLHF/3 & DVLHFSL/3**



Introduction	2
Installation.....	2
Operation.....	3
Proper Cleaning.....	3
Parts List	4
Electrical Schematic.....	5
Dinex® Warranty	6

For Service Information, call 1-888-673-4639

Please provide following information:

- Model number
- Serial number
- Part Description and number as shown in parts list.

Introduction

You have purchased the new ValuXpress® Equipment. Please read this manual for helpful guidelines on how to use your Equipment. Should you have any questions concerning the Equipment, please call the Dinex Hotline at 1-888-673-4639 (Monday through Friday from 8 am to 5 pm, Eastern Standard Time).

IMPORTANT: For your safety, read and follow all cautions, information and warnings.

FREIGHT DAMAGE CLAIMS

Your Dinex Equipment was carefully inspected and packed before leaving our plant. The transportation company assumes full responsibility for the safe delivery of the Equipment. Dinex does not assume any responsibility for damage or loss incurred in transit. Please note any visible damage or loss on the freight bill and have delivery personnel sign.

A freight claim should be filed immediately with the transportation company. If concealed damage is discovered after unpacking the Equipment, please file a concealed damage claim with the transport company within 10 days after receipt of the goods.

IMPORTANT: All packing materials should be retained for return shipment.

APPLICATION AND USE

The Equipment is for commercial use in the food service industry.

SAFETY

The instructions contained in this manual provide important guidelines for the Equipment user regarding a correct and safe installation. Particular attention should be paid to the warnings given in various parts of this manual. Never dismantle and/or repair the appliance with the power supply in place. Especially, do not repair electrical elements if you are not qualified for such work.

INFO: Please note that this appliance is for commercial use only and must be used exclusively for the purposes prescribed.

IMPORTANT: It is the responsibility of the installer to comply with all State & Local electrical codes. Connect the unit to the proper electrical power source. Check the rating tag on the unit to insure that the unit is being connected to the proper electrical power source.

CAUTION: Connecting the unit to an improper power source can cause damage to the unit and invalidate the warranty.

Installation

Carefully remove all packaging material. Units with legs have adjustable feet. Once the unit is placed in position, level the unit by screwing in or out the adjustable feet.

ELECTRICAL SPECIFICATIONS

MODEL NUMBER	AMPS		NEMA NUMBER	
	204V	208V	204V	208V
DVLHF/2 & DVLHRSL/2	8.3	8.6	6-20P	6-20P
DVLHF/3 & DVLHRSL/3	12.5	14.4	6-20P	6-20P

Operation

1. **Wet and Dry Operations:** For wet operations, make sure that the drain is closed. For wet applications, do not add more than one (1) inch of water to each foodwell. Please note that the wet operation will provide the most efficient temperature holding of the food product.
2. For wet and dry operation, cover each well with a cover, or place an empty pan in the well. Turn the thermostats to the highest setting and preheat the wells for a minimum of 45 minutes.

PROPER CLEANING

Counters must be cleaned after use or at least once daily. All food spillage must be removed.

For long equipment life:

1. **NEVER** use chlorinated or other harsh cleaners. Contrary to popular belief, stainless steel is not totally impervious. Chlorine and other harsh cleaners can cause the stainless steel units to rust, pit and corrode.
2. **NEVER** use commercial steel wool or steel wool type scouring pads. The fibers from these pads can become impregnated into the stainless steel foodwells and cause/expedite rusting, pitting & corrosion of the foodwells.
3. **ALWAYS** clean foodwells after each use or at a minimum daily with non-chlorinated cleaners approved for stainless steel. Scour each foodwell to remove all food buildup with a plastic or pure stainless steel scouring pad. Follow by a thorough rinsing and wipe dry with a soft cloth.

REPLACING THE HEATING ELEMENT

Disconnect electrical power to the unit by unplugging it! Remove all water from the foodwells. To facilitate the heating element replacement, the unit can be gently placed on its side. If this step is taken, remove the lift out bottom shelf. Very gently lay the unit on cardboard or a blanket. Remove the bottom of the unit by removing screws. Remove the bottom panel and insulation. Disconnect the electrical wiring to the heating element. Remove the heater pan assembly by removing retainer nuts. Remove faulty element and replace with new element. Install heater pan assembly with element. Connect electrical wiring to the element and install insulation and the bottom panel.

REPLACING THE FOODWELL

Disconnect electrical power to the unit by unplugging it! Remove all water from the foodwells. Remove the main control panel retainer screws. Allow panel to gently hang down. Remove the "H1" & "H2" wires from every infinite control. If the foodwells have drains, remove the drain valve located at the end of the unit. Remove screws that retain the top. Gently lift off the top. When removing the top, the foodwells, heater pan assemblies and the "H1" & "H2" wires will be removed. If the unit has drains, remove the drain fittings and tubing at the failed foodwell. Next drill out the pop rivets that retain the well. Remove the faulty well and scrap away all dried silicone sealant. Apply a generous bead of insulation onto the replacement foodwell flange and install foodwell. Attach foodwell with stainless steel pop rivets. Wipe away all excess silicone sealant. If applicable, install drain fittings/tubing and gently install the top assembly. Attach the "H1" & "H2" wires onto all infinite controls. Install the drain valve. Finally, install the insulation and bottom panel.

Parts List

DESCRIPTION	PART NUMBER
Infinite Control 208/240 VAC, 15 Amp	DX18600093
Knob, Infinite Control	DX186080026
Hi-Limit, Snap Disc Rated 225 F., 240 Volts	DX186000084
Heating Element-Not Slim Line-208/240 V., 1000/1200 Watts	DX186120388
Heating Element-Slim Line-208/240 V., 1000/1200 Watts	DX186120391
Foodwell: Heater Pan/Foodwell No Drain Assy.	DX160952842
Foodwell: Heater Pan/Foodwell With Drain Assy.	DX160952704
Foodwell Only With Drain	DX186110078
Foodwell Only With No Drain	DX186110077
Screen, Drain	DX186110082
Drain Valve, 1" NPT	DX186150189
Terminal Block	DX186070013
Adjustable Foot	DX183090031
Leg For Leveler Foot	DX160506731
Leg For Caster	DX160506736
Horizontal Support Tube For The End (Short)	DX160506732
Horizontal Support Tube (long) For DVLHF/2	DX160506735
Horizontal Support Tube (long) For DVLHF/3	DX160506733
Tube Connector (One Tube)	DX186150117
Tube Connector (Two Tube)	DX186150118
Caster Adapter Kit (1 1/2" Tube)	DX183015231
Caster, Swivel No Brake	DX183015228
Caster, Swivel with Brake	DX183015229
Bottom Shelf for DVLHF/2	DX165051013
Bottom Shelf for DVLHF/3	DX165050907
Receptacle, Optional Duplex-120 V. 15 Amp.	DX186060676

Electrical Wiring Schematic

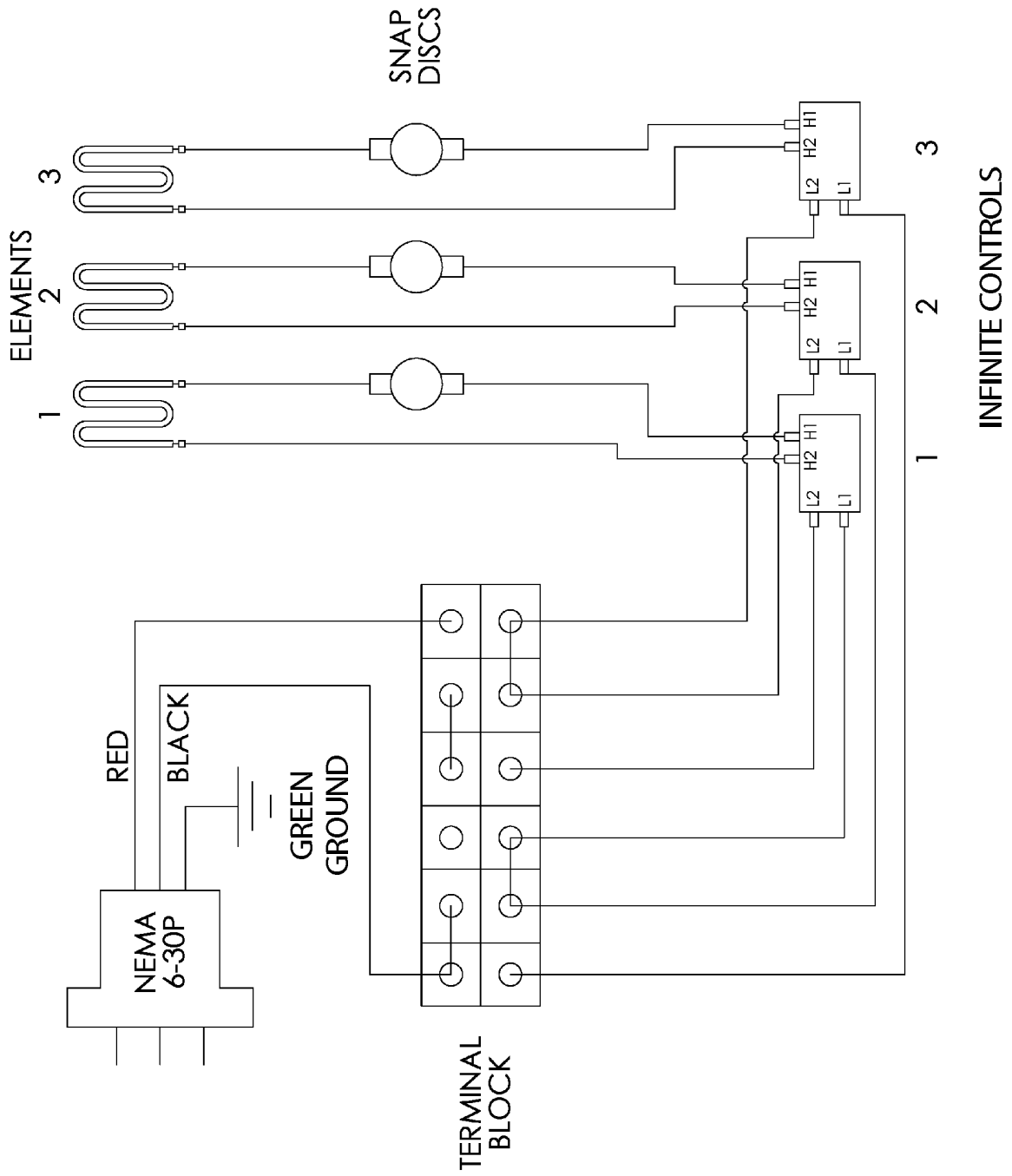

DINEX® Warranty

These Warranties cover the following Dinex International, Inc. ("Dinex") equipment products (the "Warranted Products"):

- Rethermalization Equipment Products
- Induction Heating System Products (excluding Induction Bases covered under separate warranty)
- Milk Cooler Products
- Ice Cream Freezer Products
- Air Circulate Refrigerator Products
- Blast Chiller Products
- Hot/Cold Food Counter Products
- Plate, Rack and Tray Dispenser Products
- Plate Heater Products
- Base Heater Products
- Drying and Storage Rack Products
- Starter Station Products
- Conveyer Products
- Tray and Other Cart Products

Warranted Products also includes any other Equipment System Products identified on Dinex's website (www.dinex.com) from time to time.

Standard Warranty. Except as indicated otherwise below, Dinex warrants that the Warranted Products will be free from defects in title, material and workmanship under normal use and service and will perform substantially in accordance with Dinex's written technical specifications for the Warranted Products (as such specifications exist on the date the Warranted Products are shipped) (the "Product Specifications"). This warranty covers both parts and labor and is available only to end-users (the "Customers") that purchase the Warranted Products from Dinex or its authorized distributors. For the purpose of these warranties, a defect is determined by Dinex after its good faith investigation.

Dinex Software. In addition to the other warranties set forth herein, with respect to Dinex's licensed software, Dinex warrants that it has the right to license or sublicense the software to Customer for the purposes and subject to the terms and conditions set forth in Dinex's standard terms and conditions.

Supplies and Accessories. Dinex's warranty for its supplies and accessories that are shipped with Warranted Products is covered by a separate warranty statement, which is available at www.dinex.com.

Services. Dinex warrants that any service it provides to Customer will be performed by trained individuals in a workmanlike manner.

DURATION

Dinex provides a one year warranty for the Warranted Products. The warranty period begins on the date the Warranted Products are shipped to Customer. The warranty period for any Warranted Product or part furnished to correct a warranty failure will be the unexpired term of the warranty applicable to the repaired or replaced Warranted Product.

REMEDIES

If Customer promptly notifies Dinex of Customer's warranty claim and makes the Warranted Product available for service, Dinex will, at its option, either repair or replace (with new or exchange replacement parts) the non-conforming Warranted Product or parts of the Warranted Product. With respect to Dinex's licensed software, Dinex will, at its option, either correct the non-conformity or replace the applicable licensed software. Warranty service will be performed without charge from 8:00 a.m. to 5:00 p.m. EST, Monday-Friday, excluding Dinex holidays, and outside those hours at Dinex's then prevailing service rates and subject to the availability of personnel. With respect to Dinex's warranty for the services it provides to Customer, Customer's exclusive remedy shall be the re-performance of the services by Dinex.

The foregoing remedies are Customer's exclusive remedies and Dinex's sole liability for warranty claims under this warranty statement. This exclusive remedy shall not have failed of its essential purpose (as that term is used in the Uniform Commercial Code) as long as Dinex remains willing to repair or replace defective Warranted Products within a commercially reasonable time after being notified of Customer's warranty claim.

LIMITATIONS

THESE WARRANTIES ARE EXCLUSIVE AND IN LIEU OF ALL OTHER WARRANTIES, WHETHER WRITTEN, ORAL, EXPRESSED, IMPLIED OR STATUTORY. EXCEPT AS PROVIDED HEREIN, NO EXPRESS OR IMPLIED WARRANTIES, INCLUDING BUT NOT LIMITED TO IMPLIED WARRANTIES OF MERCHANTABILITY, FITNESS FOR A PARTICULAR PURPOSE, QUIET ENJOYMENT, SYSTEM INTEGRATION AND DATA ACCURACY, WILL APPLY. THERE ARE NO WARRANTIES THAT EXTEND BEYOND THOSE DESCRIBED IN THIS DOCUMENT AND NO PRIOR STATEMENTS BY ANY OF DINEX'S REPRESENTATIVES SHALL MODIFY OR EXPAND THESE WARRANTIES. DINEX AND DINEX'S AFFILIATES AND REPRESENTATIVES SHALL HAVE NO LIABILITY TO CUSTOMER FOR (1) ANY SPECIAL, PUNITIVE, INCIDENTAL, INDIRECT OR CONSEQUENTIAL DAMAGES ARISING OUT OF OR IN CONNECTION WITH THE WARRANTED PRODUCTS, REGARDLESS OF WHETHER SUCH LIABILITY SHALL BE CLAIMED IN CONTRACT, TORT, EQUITY OR OTHERWISE, (2) ANY ASSISTANCE NOT REQUIRED UNDER DINEX'S QUOTATION OR (3) ANYTHING OCCURRING AFTER THE WARRANTY PERIOD ENDS.

DINEX'S STANDARD WARRANTIES ONLY APPLY TO END-USER-PURCHASERS LOCATED IN THE UNITED STATES AND CANADA. ANY SALE TO END-USER-PURCHASERS OUTSIDE THE UNITED STATES AND CANADA WILL BE SUBJECT TO COMMERCIAL TERMS SPECIFICALLY AGREED BY DINEX AND THE END-USER PURCHASER. DINEX MAKES NO WARRANTY, EXPRESS OR IMPLIED, TO END-USER-PURCHASERS OUTSIDE THE UNITED STATES OR CANADA UNLESS OTHERWISE EXPRESSLY AGREED IN WRITING.

These warranties do not apply to, and Dinex shall not have any obligation to Customer hereunder with respect to, any warranty claim resulting from or arising out of: (i) normal wear and tear; (ii) damage caused by shipping or accident; (iii) damage caused by improper installation, repair or alteration not performed by Dinex; (iv) the use of the Warranted Product in combination with any software, tools, hardware, equipment, supplies, accessories or any other materials or services, not furnished by Dinex or recommended in writing by Dinex; (v) the use of the Warranted Product in a manner or environment, or for any purpose, for which Dinex did not design or license it, or inconsistent with Dinex's recommendations or instructions on use including, but not limited to, power supply requirements identified in Product Specifications; (vi) any alteration, modification or enhancement of the Warranted Product by Customer or any third party not authorized or approved in writing by Dinex; (vii) Warranted Product manufactured to meet customer specifications or designs; or (viii) any accessories or supplies or other equipment or products that may be delivered with the Warranted Product.

In addition, these warranties do not cover: (i) Any defect or deficiency (including failure to conform to Product Specifications) that results, in whole or in part, from any improper storage or handling, failure to maintain the Warranted Products in the manner described in any applicable instructions or specifications, inadequate back-up or virus protection or any cause external to the Warranted Products or beyond Dinex's reasonable control, including, but not limited to, power failure and failure to keep Customer's site clean and free of dust, sand and other particles or debris; (ii) the payment or reimbursement of any facility costs arising from repair or replacement of the Warranted Products; (iii) any adjustment, such as alignment, calibration, or other normal preventative maintenance required of Customer; and (iv) expendable supply items.

DINEX[®]

DINEX INTERNATIONAL, INC.

WWW.DINEX.COM

628-2 HEBRON AVENUE, GLASTONBURY CT 06033 • 1.800.523.9752